

UMS-92 Daily Maintenance Stand

Specification Sheet

Specifications

Part Number	SPUM-4175
Load Rating	800 lbs (363 kg) per deck 400 lbs (181 kg) per stair
Material	Primarily 6061 and 6063 aluminum
Stair	Variable pitch
Caster	Split-tread swivel
Actuation	Manual
Standard Warranty	3 years
Air Supply	Yes; above deck
Electric Supply	Not standard; may be added
On GSA	No



Two stands and one staircase shown

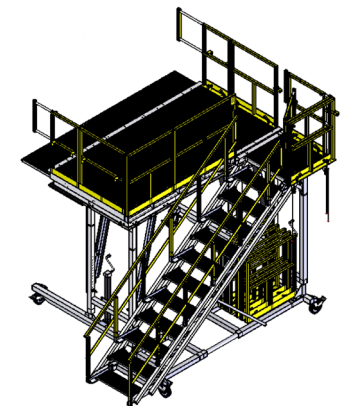
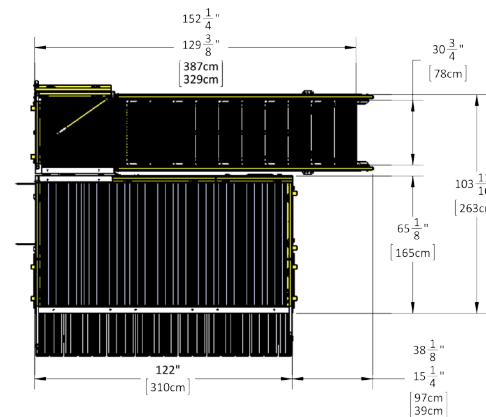
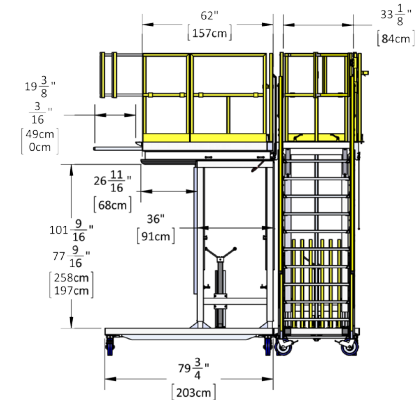
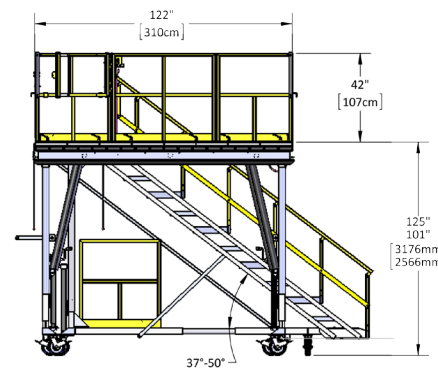

ABOUT SPIKA

Spika Welding and Manufacturing specializes in designing and manufacturing the highest quality work platforms and ground support equipment in the world. Our expert design team guarantees OSHA compliance and an improved work environment, and we excel not only at off-the-shelf products designed for specific applications, but also at one-off and specialty designs. At Spika, we are continually innovating to provide our customers with a product and service that exceeds their expectations. Our commitment to customer satisfaction is our ultimate priority; if you're not happy, our job isn't done.